

D2 W LR

Quick Start Guide

Wireless I/O Receiver Unit

SAVE THESE INSTRUCTIONS FOR FUTURE REFERENCE

About this Document

This document is the *Cooper Crouse-Hinds D2 W LR Wireless I/O Receiver Unit Quick Start Guide* and contains the following sections:

Section	Read this section if you want to ...
Basic Steps for Using your Unit	Learn the basic steps for installing and using your unit.
Factory Default Configuration	Understand how the transmitter sends information to the receiver.
Unit Components	Understand the different parts of your unit.
Antenna Installation	Learn how to install an antenna with your unit.
Resetting Factory Defaults	Reset your unit to the original factory default settings.
Linking Transmitter and Receiver Units	Link your units to work as a dedicated pair.
Safety Information	Understand important safety information related to your unit. NOTE: You must read this information before installing your unit.
Specifications	Know technical information about your unit.

For more information, see the next sections.

Basic Steps for Using your Unit

This document describes how to configure your unit using the default factory configuration that lets you easily set up your network as a simple send/receive network using a dedicated pair of transmitter and receiver units.

The basic steps for using your unit are:

1. Connect the antenna power supply and transducer signals using the instructions in this document. Power supply and transducer connection is described in the section, **Unit Components and Connections**. Antenna connection is described in the section, **Antenna Installation**. For more information, see the **D2 W LT and D2 W LR Instruction Sheet**.
2. Reset the transmitter and receiver units to the factory default configurations.
3. Link the transmitter and receiver units to work as a dedicated pair.
4. Bench test your configuration before deploying.

NOTE: You can also configure your network using a user-defined customized configuration that lets you set specific information about your network. For more information on setting a user-defined customized configuration, see the **D2 W LT and D2 W LR Instruction Sheet** on the enclosed CD.

Factory Default Configuration

When you configure the units using the configuration in this document, the inputs from the transmitter are sent to the outputs at the receiver as follows:

D2 W LT (Transmitter)	Sends	D2 W LR (Receiver)
Digital Input 1	⇒	Digital Output 1
Digital Input 2	⇒	Digital Output 2
Analog Set-point	⇒	Digital Output 3
Analog Input (4-20 mA)	⇒	Analog Output (4-20 mA)
Thermocouple Input (not used)		Communication Failure (comes on if no messages from D2 W LT)
Set-point Output (local indication)		
System OK (on if system OK)		System OK (on if system OK)

Unit Components and Connections

Your D2 W LR receiver unit has the following components and terminal connections:

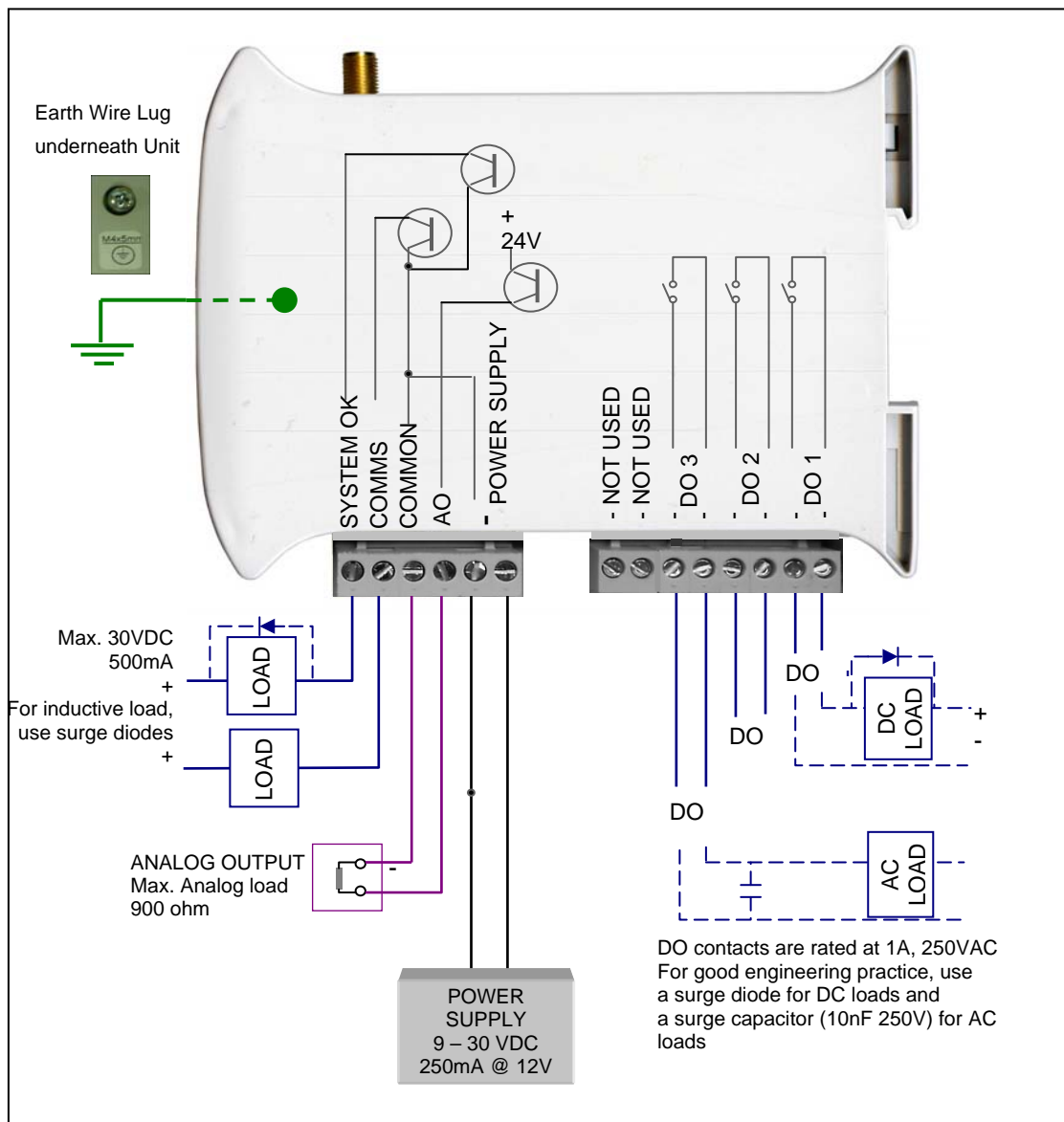

****IMPORTANT ELECTRICAL SAFETY INFORMATION****

In order to comply with Electrical Safety Regulations, this module must be installed in an Electrical AND Fire enclosure. This enclosure may be a single or multiple enclosures. Access to the module is to be made by a Service Person only.

In order to comply with Electrical Safety Standards, when connecting SELV AND voltages which are greater than SELV (30VAC or 60VDC) together, then Relay Output 2 must NOT be used in order to provide sufficient isolation between the outputs

The front panel contains the following components:

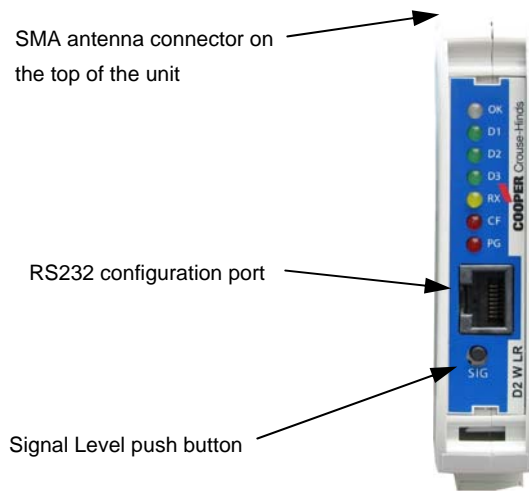

The LED's on the front panel indicate the unit status:

LED Status	Indicates			
None	No power supply.			
OK LED Green	Current status of the unit OK.			
OK LED Red	Fault condition detected in unit.			
RX Led Flashes	Receiving message.			
CF LED ON	Module communication failure output is active.			
PG LED ON	Configuration cable connected.			
Output LED ON	The Output LED's (i.e. D1, D2, D3) light when the corresponding output is active.			
	D1	Relay output D1 is ON (contact closed).		
	D2	Relay Output D2 is ON.		
	D3	Relay Output D3 is ON.		
LED's with RSSI Pushbutton Pressed	When you press the RSSI pushbutton, the unit shows the signal strength by lighting the LED's from the bottom to the top. Signal strength is the strength of the last message received that was addressed to this station.			
	LED	Signal Strength	LED	Signal Strength
	D1	More than -85 dBm	RX	More than -100 dBm
	D2	More than -90 dBm	CF	More than -105 dBm
	D3	More than -95 dBm	PG	Always on during RSSI test
Output LED Flashing Quickly	If an output is in communication failure, the corresponding LED flashes at 5 Hz.			
	D1	Relay Output D1 is in communication failure.		
	D2	Relay Output D2 is in communication failure.		
	D3	Relay Output D3 is in communication failure.		
	PG	Analog Output is in communications failure.		

Antenna Installation

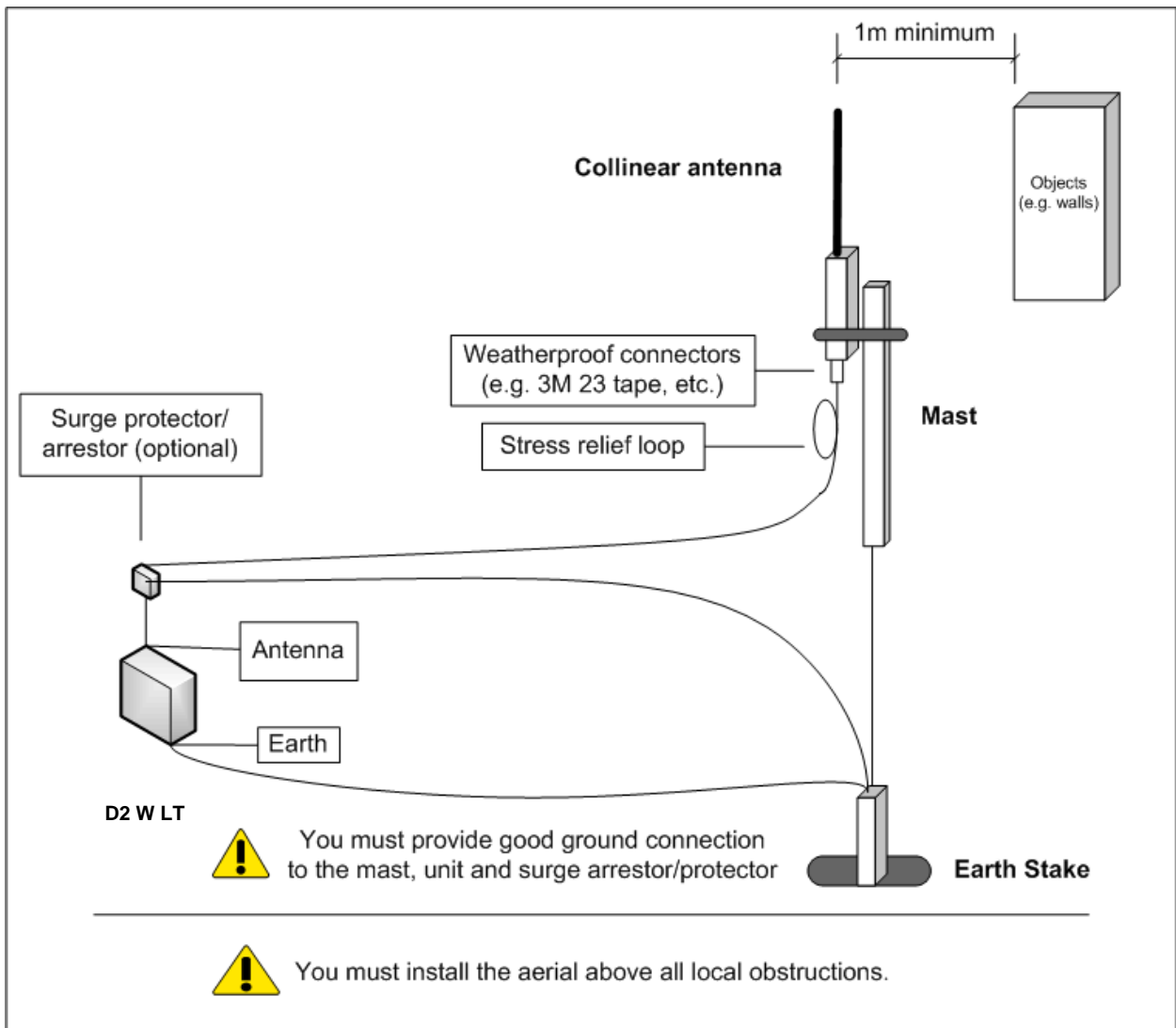

Resetting your Receiver Unit to Factory Defaults

You must reset the receiver unit to factory defaults before linking the transmitter and receiver units.

To reset the default factory configuration:

1. Press and hold the RSSI pushbutton.
2. Power on the D2 W LR receiver.
3. The D2 W LR receiver flashes all LED's at medium flash (i.e. 1.6 Hz).

NOTE: If the LED's do not flash, you must repeat steps 1 and 2 until the LED's flash before continuing.

4. Release the RSSI pushbutton within 5 seconds.
5. Within a further 60 seconds, press and hold the RSSI pushbutton for 5 seconds (until the LED's stop flashing) and then release.
6. The D2 W LR receiver lights all LED's for 2 seconds before returning to normal operation.

NOTE: If the LED's do not light, you must repeat the process from Step 1 until the LED's light before continuing.

7. You can now link the transmitter and receiver units.

Linking your Transmitter and Receiver Units

You must reset the transmitter unit to factory defaults (to disable encryption) before linking the transmitter and receiver units. For more information, see the ***D2 W LT Transmitter Quick Start Guide***.

NOTE: You must complete the linking process in 60 seconds.

To link the transmitter and receiver units:

1. Press and hold down the RSSI pushbutton on the receiver.
2. Power on the receiver while holding down the RSSI pushbutton.
3. Release the RSSI pushbutton as soon as the Receiver LED's flash (within 5 seconds of powering the receiver).
4. The receiver will flash all LED's for a maximum 60 seconds while it tries to link to the transmitter.
5. Power on the transmitter. The transmitter sends a special "Link" message to allow the receiver to recognize the transmitter.
6. When the units link, the receiver lights all LED's for 2 seconds before returning to normal operation.

NOTE: If the receiver LED's continue flashing within the 60 seconds, the units are not linked and you should retry the linking process by powering the transmitter off and on again. If you exceed the 60 seconds, you must restart the linking process from Step 1.

7. You can now bench test your configuration before deploying.

Safety Information

Thank you for selecting the D2 W LR receiver for your telemetry needs. We trust it will give you many years of valuable service. To ensure D2 W LR receiver enjoys a long life, double-check **ALL** your connections with the Instruction Sheet before powering on the unit.

WARNING: Incorrect termination of supply wires may cause internal damage and will void warranty.

Exposure to RF energy is an important safety consideration. The FCC has adopted a safety standard for human exposure to radio frequency electromagnetic energy emitted by FCC regulated equipment as a result of its actions in Docket 93-62 and OET Bulletin 65 Edition 97-01.

FCC Notice when Used in USA: D2 W LR Wireless I/O Receiver Module

Part	Additional Information
15	This device has been tested and found to comply with the limits for a Class B digital device, pursuant to Part 15 of the FCC rules (Code of Federal Regulations 47CFR Part 15). Operation is subject to the condition that this device does not cause harmful interference.

Industry Canada: D2 W LR Wireless I/O Receiver Module

This device has been type accepted for operation by Industry Canada. See the label on the unit for the specific Industry Canada certification number and any other certification designations.

NOTE: Any changes or modifications not expressly approved by Cooper Crouse-Hinds could void the user's authority to operate this equipment.

Safety Information - FCC Notice

This device complies with Part 15.247 of the FCC Rules. Operation is subject to the following two conditions:

- This device may not cause harmful interference; and
- This device must accept any interference received, including interference that may cause undesired operation.

NOTE: This equipment is suitable for use in Class I, Division 2, Groups A, B, C, D; Temperature Code T4A or non-hazardous locations only.

Unit Specifications

Input/Output	Number	Additional Information
Digital Outputs	3	Voltage-free contacts rated at 250 VAC 1A, 30VDC 1A. 2 for digital inputs and 1 for set-point.
Status Outputs	2	Separate system OK and communication failure output.
Analog Output	1	16-bit resolution, 0.1% accuracy, single-ended source output.
Power Supply	1	9-30 VDC 0.25 Amp CSA Certified Class 2 power supply. For use in Class I, Div 2 explosive areas, the power supply must be approved for Class I, Div 2 use. WARNING: Explosion hazard - do not disconnect while circuit is live unless area is known to be non-hazardous.
Radio Receiver	1	High sensitivity FHSS UHF radio receiver.
Frequency	902 – 928 MHz	Actual frequency range depends on country.
Sensitivity	-110 dBm	At PER (Packet Error Rate) 8%.